

VERSALIFT VTL-140-F

Chassis mounted telescopic platform



Mercedes-Benz Sprinter
(3,500 kg GVW)



Available for class B
driving licence



FPC controls with up to
4 actions at a time



Emergency lowering
controls at the pedestal



Knuckle/turret tailswing
within the mirrors



1 kV certified low
voltage insulation

Available specifications



Dimensions



Length: 7,148 mm **Height:** 3,200 mm **Wheelbase:** 3,665 mm

Additional equipment

- Outrigger pads with holders
- Hydraulic axle locking system
- Cabinet for the chassis
- Sideboards for the chassis
- Bucket rotator (2 x 90°)***
- Inverter
- Reversing camera
- Drive option (drive the vehicle with raised platform)****
- Load cell (Variable load dependant outreach)
- Home function & limited working area without outriggers

Diagramme(s)

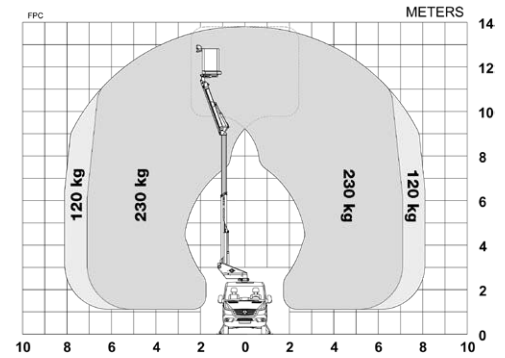

Working envelope

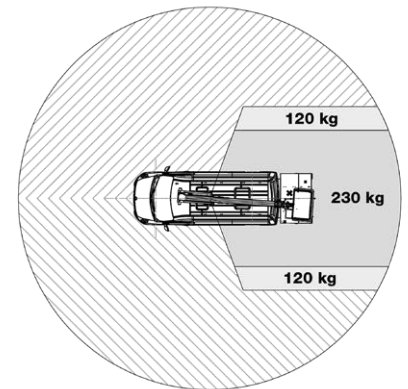

Limited working area without outriggers (optional)

Key features



The shaped profile ultra high strength steel booms provide improved rigidity, stiffness and performance



Ground level emergency lowering from the chassis (pedestal mounted valve bank)



Cabinet for the chassis (optional)



FPC (Full Proportional CANbus controls): Variable outreach (with load cell) and up to 4 actions at a time

Notes

Technical information is subject to change without prior notice. Images may show optional equipment. Installations and/or options may not be available in your specific region.

* Depending on the vehicle.

** Max payload with a driver, a passenger and a full tank of fuel (220 kg added to the installation weight).

*** Reduced outreach. May require axle lock.

**** Requires the option "Limited working area without outriggers".

Distributor

C930F (Versalift VTL-37-140-F on Mercedes-Benz Sprinter Chassis) - revision 2018/10

www.TimeIntl.dk