



LAT-38-140-H

LOW VOLTAGE
TRACK MOUNTED PLATFORM



FULLY
HYDRAULIC
CONTROL



ARTICULATED
BOOM



WALK-IN BUCKET

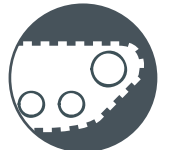

TRACKED CHASSIS



10° LEVELLING



5.6 MPH / 9.0 KPH
TRACKING SPEED



SPECIFICATIONS

Working height	14.0m
Platform height	12.0m
Max. outreach	6.3m
Max. bucket capacity	230kg
Flyboom	Fixed
Combined weight*	4150kg
Max. slope	3° / 5°

*Subject to options fitted

STANDARD

- Mounted on a Morooka MST300VD tracked chassis
- ROPS Canopy
- Articulating, telescopic platform
- Fully hydraulic proportional control
- Safe access to bucket from ground or chassis
- Low voltage insulated platform - 1kV certified insulation
- 12V DC emergency lowering system
- Emergency manual hand pump
- Ring of steel mainframe
- A-frame outriggers (front and rear), 800mm stroke
- 10 degree levelling capability
- Four lifting eyes for craning
- Four spreader pads with carrying frames
- Electric parking brake
- "T" handle control lever
- Kubota 48ps (35.6kW) diesel engine - interim T4
- 'Ride on' tracking speed of 5.6mph/9.0kph
- Forward and reverse facing seat positions
- Deck space for transportation of tools and equipment

OPTIONS

- Choice of GRP walk-in bucket or aluminium basket
- Bespoke storage lockers
- LED chassis lighting
- Amber LED beacons
- Hi-Vis chevrons

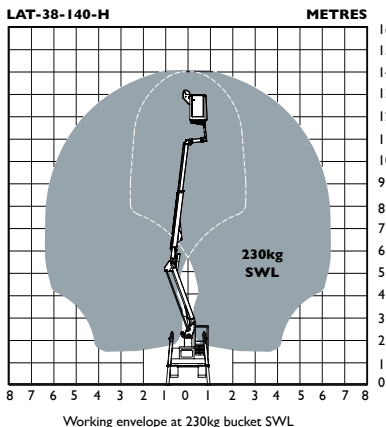

Platform mounted on a Morooka MST300VD



Safe access to bucket from ground or Morooka chassis



Easy to use fully hydraulic proportional control



Hydraulic and 12V DC emergency ground controls with hand pump for improved safety



High 'Ride on' tracking speed of 5.6mph/9.0kph



Capable of levelling on slopes up to 10°

The photographs in this brochure are for promotional purposes only. Specifications are subject to change without notice.



1 Altendiez Way,
Latimer Park,
Burton Latimer,
Kettering, NN15 5YT
T: 01536 721010
F: 01536 721111
E: sales@versalift.co.uk
W: www.versalift.co.uk



Revision: 05/16/01

