

VTP-40-NE

Cable Placer Non-Insulated

nescoTM
SPECIALTY RENTALS

- **WORKING HEIGHT:** Up to 40 ft (12.2 m)
- **HORIZONTAL REACH:** Up to 29 ft 7 in (9.0 m)
- **PLATFORM CAPACITY:** Up to 500 lbs (226 kg)



BEST
SIDE REACH &
PLATFORM SIZE

FULL
PRESSURE,
SINGLE STICK
CONTROLS

600 LBS
SIDE PULL
CAPACITY

VTP-40-NE model shown here.

VERSALIFT[®]

TruGuard[®] Patented Safety System - 5" Electrical Isolation

- Only insulated unit to offer fully hydraulic controls
- Includes control dash panel & tool circuit
- Robust, durable & familiar metal handle
- Dirty surfaces and work gloves don't impact the isolation system

VTP-40-NE

Cable Placer Non-Insulated



GENERAL SPECIFICATIONS:

Horizontal Reach	29 ft 7 in (9.0 m)
Platform Capacity	500 lbs (226 kg)
Cable Down Load Capacity	150 lbs (68 kg)
Total Unit Capacity (Platform + Cable Down Load)	500 lbs (226 kg)
Side Pull Capacity (Fairlead retracted)	600 lbs (270 kg)
Side Pull Capacity (Fairlead extended)	450 lbs (200 kg)
Outer/Inner Boom Travel	-20° to +80°
Inner Boom Extension	110 in (2.8 m)
Rotation	370° Non-Continuous

WITH 40 IN. (1.02 M) TALL PEDESTAL (Standard):

Height to Bottom of Platform	35 ft (10.7 m)
Working Height	40 ft (12.2 m)
Stowed Travel Height	11 ft 6 in (3.5 m)
Weight of Lift	3400 lbs (1540 kg)

HYDRAULIC SYSTEM:

Operating Pressure	2250 psi (155 bar)
Flow Rate	12 gpm (45 lpm)
Filtration	10 micron return 100 mesh suction
System Type	Closed Center
Power Source	PTO Pump

OPTIONS:

- Backup 12-Volt Pum
- Fairleads
- Capstan Winch
- Hydraulic Tool Ports
- Tool Trays
- Various Ropes

FEATURES:

- Transferrable Fairlead Support
- Rear Reel Drive
- Strand Drives
- Bull Wheel Cable Guide
- Reel Lift (6000 lb max)
- Strand Carrier (28 in wide/32 in dia)

- Lift Eye (2000 lb max)
- Reel Tensioning Brakes
- Strand Tensioning Brakes
- Intercom System
- Tow Line Winch with 70 ft Rope (21 m)

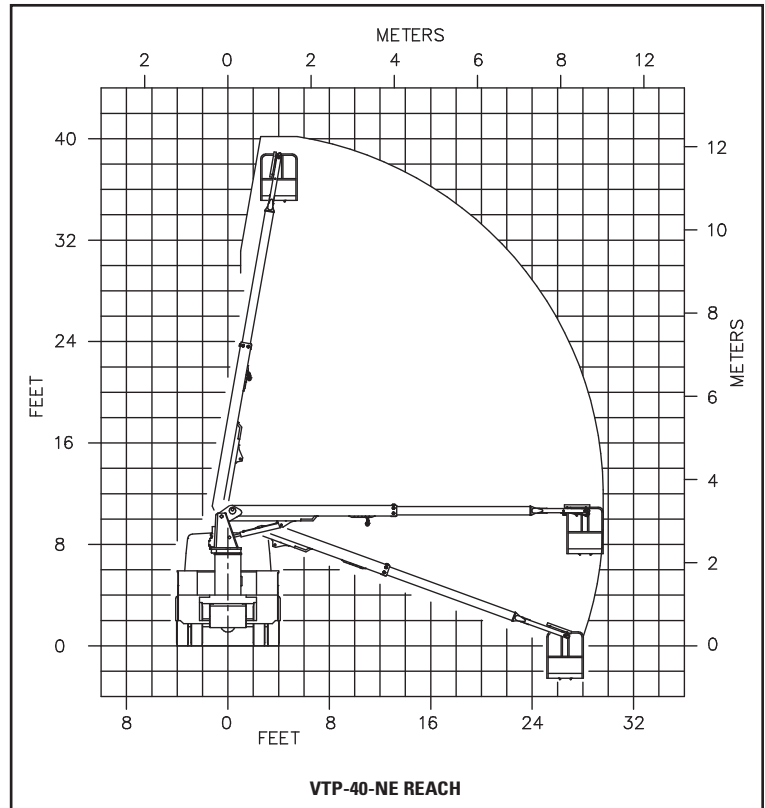

Note: Specifications on units may vary or change without prior notification due to option selections.

REV. 03/20

VERSALIFT is a leading manufacturer of bucket trucks, digger derricks and cable placers. Customers in the electric utility, telecommunications, forestry and sign, light & traffic industries experience a lower true cost of ownership by choosing Versalift. Our equipment is engineered to be lighter, while keeping the designs simple, which provides advantages like less unscheduled maintenance, greater payloads and ease of maintenance. Versalift has the lowest recall rate in the industry making it the smarter and most reliable choice. Versalift aerial lifts are the only units to feature the patented TruGuard® safety system, which provides additional protection to linemen in the bucket. Versalift is a Time Manufacturing Company, and together with Aspen Aerials has more than 1,400 employees worldwide.