

SST-36-N/NE

Lightweight Telecommunications Workhorse

- **WORKING HEIGHT:** Up to 40 ft 6 in (12.3 m)
with Standard Pedestal
- **HORIZONTAL REACH:** Up to 26 ft 7 in (8.1 m)
- **PLATFORM CAPACITY:** Up to 400 lbs (181 kg)

**BEST IN
CLASS
PAYLOAD**

**PREFERRED
FOR LEADING
TELECOM
PROVIDERS**



SST-36-NE model shown here.

VERSALIFT®

**LOWER TRUE
COST OF
OWNERSHIP**

SST-36-N/NE

Lightweight Telecommunications Workhorse



GENERAL SPECIFICATIONS:

(Based on 40 in Frame)

Horizontal Reach

SST-36-N 24 ft 8 in (7.5 m)

SST-36-NE 26 ft 7 in (8.1 m)

Standard Platform Capacity 350 lbs (160 kg)

Max Platform Capacity (-NE only) 400 lbs (181 kg)

WITH STANDARD PEDESTAL:

Height to Bottom of Platform 35 ft 6 in (10.8 m)

Working Height 40 ft 6 in (12.3 m)

Stowed Travel Height 10 ft 5 in (3.2 m)

BOOM ACTION:

Inner Boom Extension 116 in (2.9 m)

Inner/Outer Boom Articulation -14° to +74°

Lower Boom Articulation -6° to Vertical

HYDRAULIC SYSTEM:

Operating Pressure 2250 psi (155 bar)

Flow Rate 2 gpm (7.57 lpm)

System Type Open Center

OPTIONS:

- Hydraulic Platform Leveling (Standard on -NE)
- Backup 12-Volt Pump
- Rear Torsion Bar
- Independent H Frame Outriggers
- Hand-Held Remote Lower Control
- 120 Volt Receptacle at Platform
- Two Speed Boom Controls
- Various Platforms, Liners and Covers
- Various Pedestal Heights
- Pneumatic Circuit to the Platform
- Lift Eye (500 lb max)
- Emergency Lowering
- Automatic Boom Latch

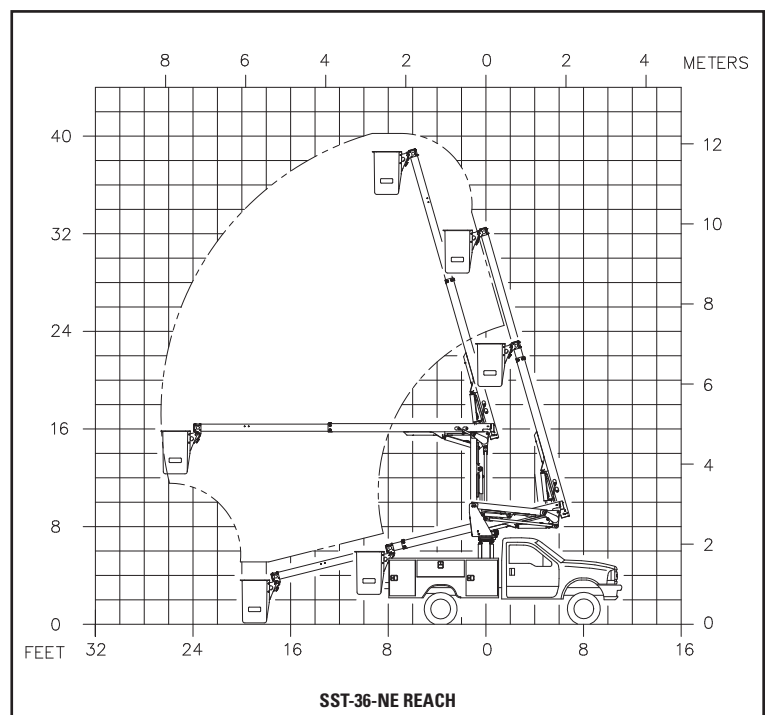
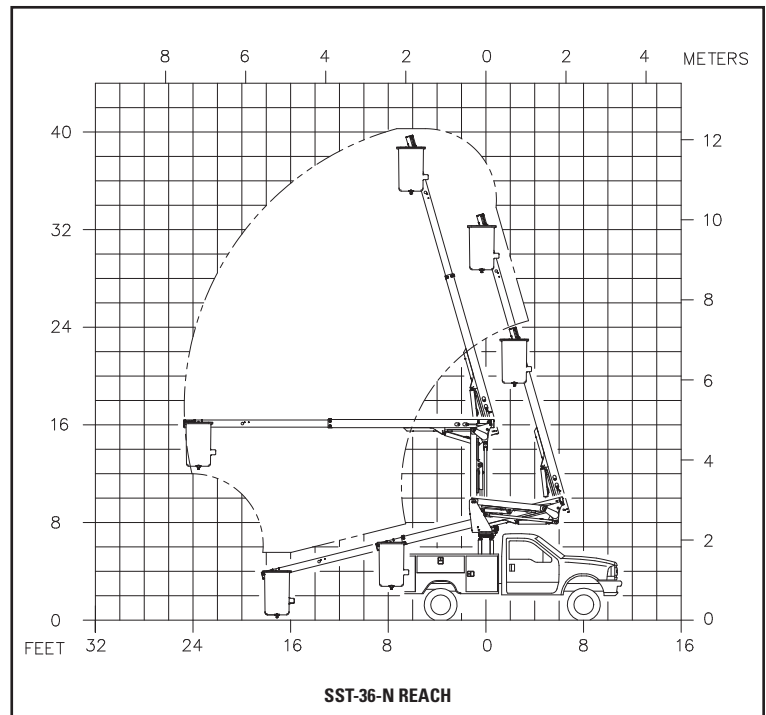

Note: Specifications on units may vary or change without prior notification due to option selections.

REV. 03/20

VERSALIFT is a leading manufacturer of bucket trucks, digger derricks and cable placers. Customers in the electric utility, telecommunications, forestry and sign, light & traffic industries experience a lower true cost of ownership by choosing Versalift. Our equipment is engineered to be lighter, while keeping the designs simple, which provides advantages like less unscheduled maintenance, greater payloads and ease of maintenance. Versalift has the lowest recall rate in the industry making it the smarter and most reliable choice. Versalift aerial lifts are the only units to feature the patented TruGuard® safety system, which provides additional protection to linemen in the bucket. Versalift is a Time Manufacturing Company, and together with Aspen Aerials has more than 1,400 employees worldwide.