

# SST-37/40-EIH

*Insulated Lightweight Workhorse*

- **WORKING HEIGHT:** Up to 45 ft (13.7 m)  
with Standard Pedestal
- **HORIZONTAL REACH:** Up to 27 ft 9 in (8.5 m)
- **PLATFORM CAPACITY:** Up to 450 lbs (204 kg)

**FULL  
PRESSURE  
HYDRAULIC  
CONTROLS**

**BEST  
IN CLASS  
PAYLOAD**



*SST-40-EIH model shown here.*

**VERSALIFT®**

**LOWER TRUE  
COST OF  
OWNERSHIP**

# SST-37/40-EIH

Insulated Lightweight Workhorse



## GENERAL SPECIFICATIONS:

(Based on 40 in Frame)

Horizontal Reach 27 ft 9 in (8.5 m)

Maximum Platform Capacity 450 lbs (204 kg)

## WITH STANDARD PEDESTAL:

Height to Bottom of Platform

SST-37-EIH 37 ft (11.3 m)

SST-40-EIH 40 ft (12.2 m)

Working Height

SST-37-EIH 42 ft (12.8 m)

SST-40-EIH 45 ft (13.7 m)

Stowed Travel Height

10 ft 4 in (3.15 m)

## INSULATION GAP:

Upper Boom Fully Retracted 42 in (1.07 m)

Lower Boom Insert (optional) 12 in (0.3 m)

Upper Boom Fully Retracted 10 in (.25 m)

(w/o Electrogard)

## HYDRAULIC SYSTEM:

Operating Pressure 2250 psi (155 bar)

Flow Rate 5 gpm (18.9 lpm)

System Type Open Center

## BOOM ACTION:

Inner Boom Extension 116 in (2.9 m)

Outer Boom -14° to +74°

Lower Boom

SST-37-EIH -7° to Vertical

SST-40-EIH -5° to Vertical

Rotation

370° Non-Continuous

## OPTIONS:

- 4-Axis Controller
- Continuous Rotation
- Rear Torsion Bars
- Independent Outriggers
- Backup 12-Volt Pump
- Engine Throttle Control
- Lift Eye (500 lb max)
- Automatic Boom Latch
- 180° Rotating Platform
- Hydraulic Tool Circuit at the Platform

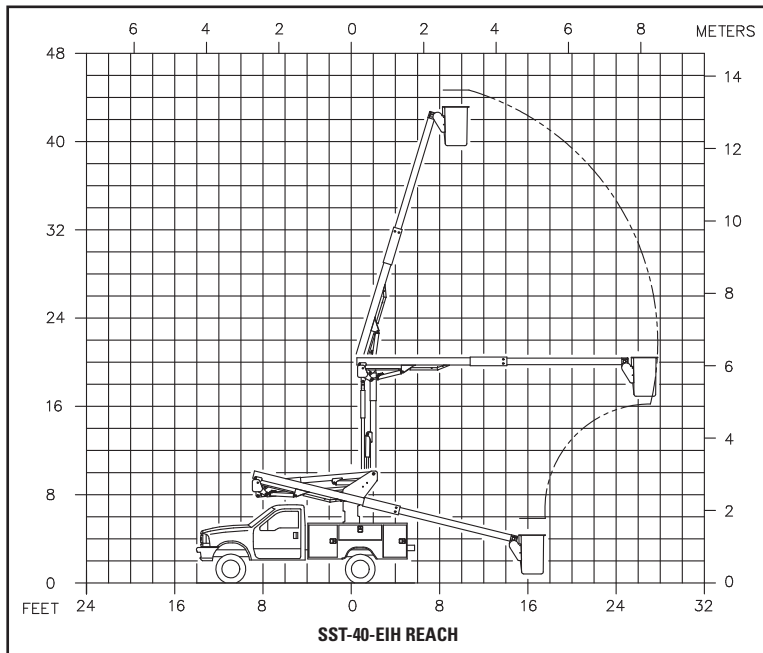
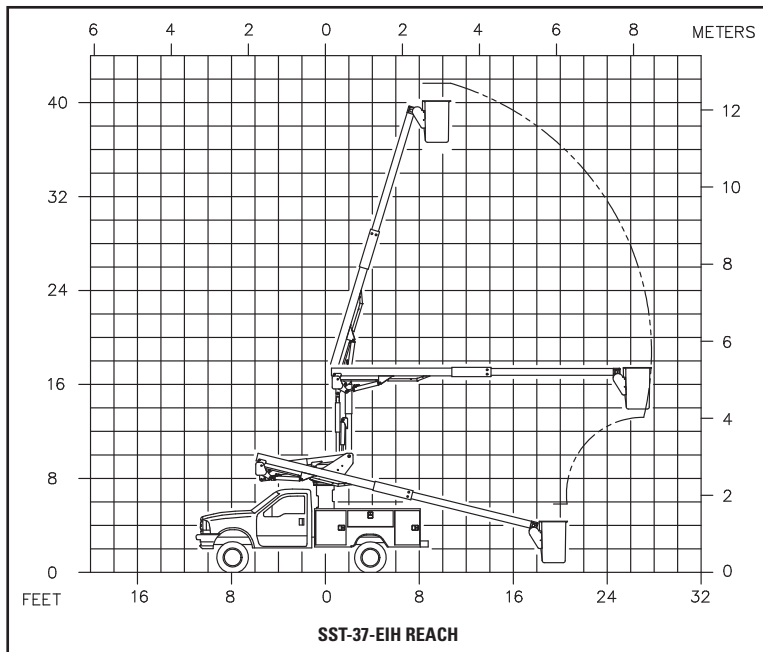

Note: Specifications on units may vary or change without prior notification due to option selections.

REV. 03/20

**VERSALIFT** is a leading manufacturer of bucket trucks, digger derricks and cable placers. Customers in the electric utility, telecommunications, forestry and sign, light & traffic industries experience a lower true cost of ownership by choosing Versalift. Our equipment is engineered to be lighter, while keeping the designs simple, which provides advantages like less unscheduled maintenance, greater payloads and ease of maintenance. Versalift has the lowest recall rate in the industry making it the smarter and most reliable choice. Versalift aerial lifts are the only units to feature the patented TruGuard® safety system, which provides additional protection to linemen in the bucket. Versalift is a Time Manufacturing Company, and together with Aspen Aerials has more than 1,400 employees worldwide.