

RUTHMANN T 295 A

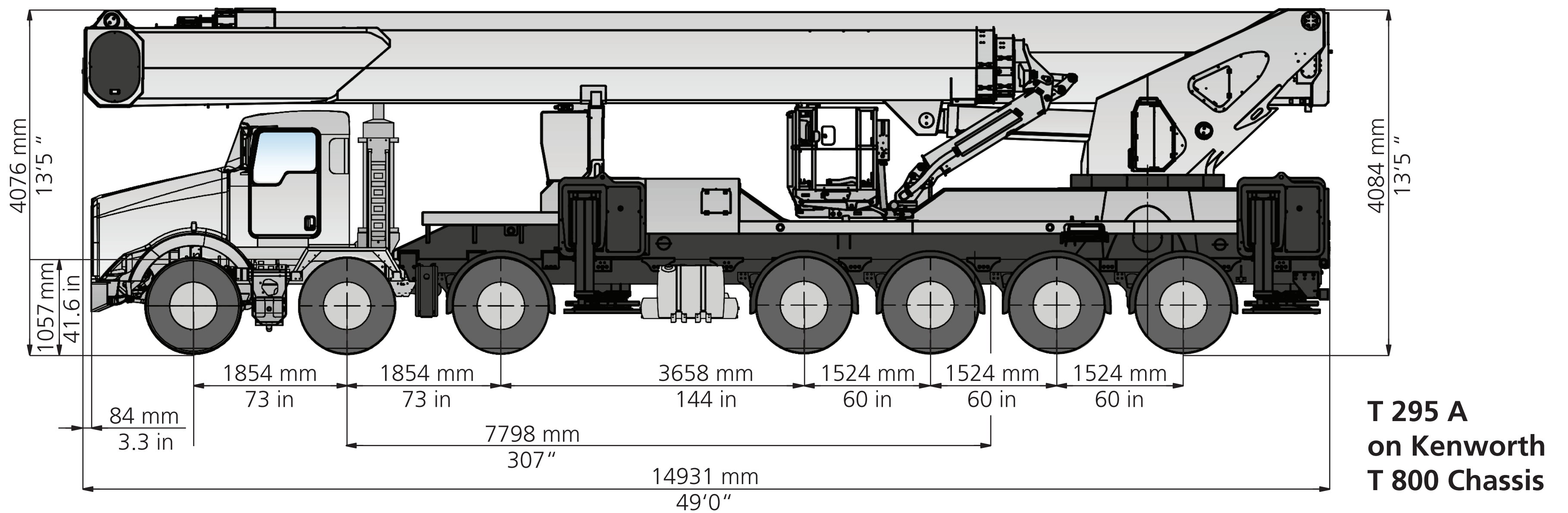
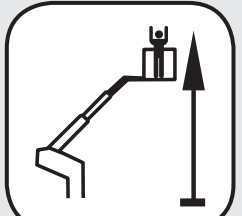
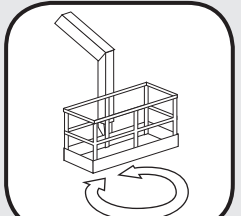
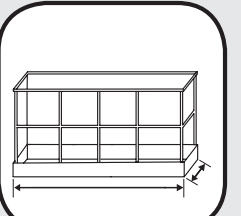
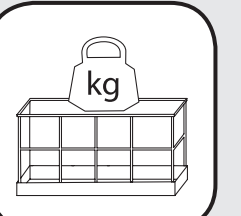
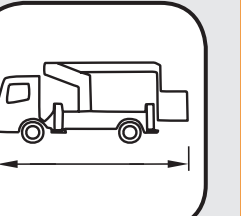
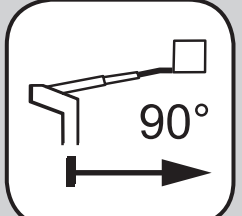
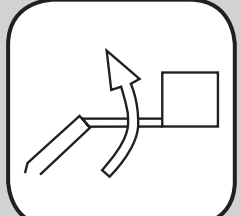
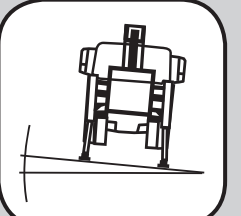
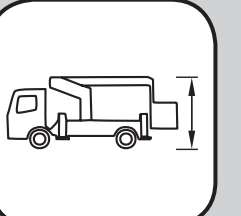
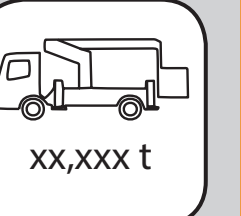

RUTHMANN T 295 A

	295 ft 90 m		440°		12.5 x 3.2 ft 3.82 x 0.97 m		1300 lbs 590 kg		49'3" 15 m
	137 ft 41.8 m		220°		1°		13'6" 4.11 m		115,000 lbs 52,163 kg xx,xxx t

SKY performance mode

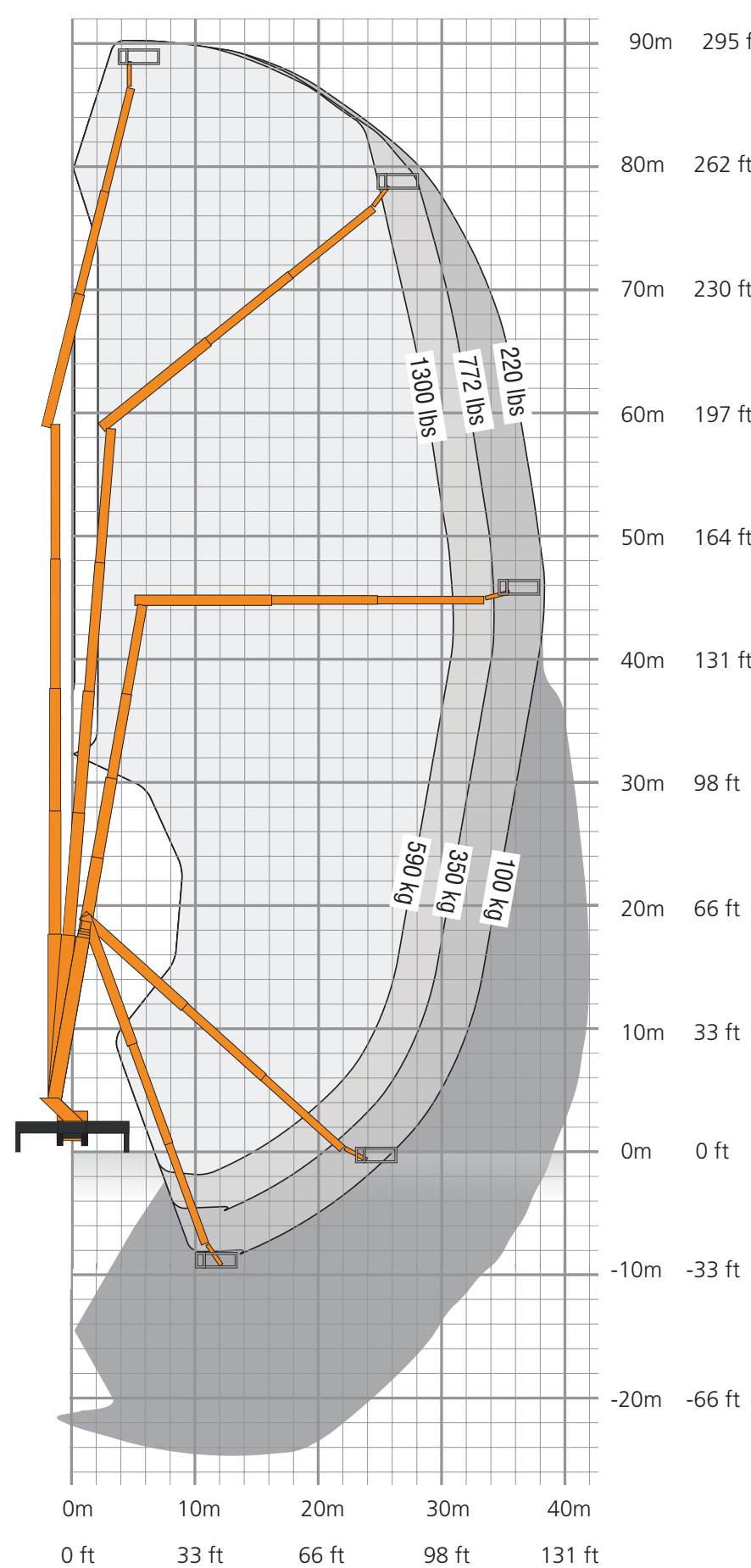

HEIGHT performance mode

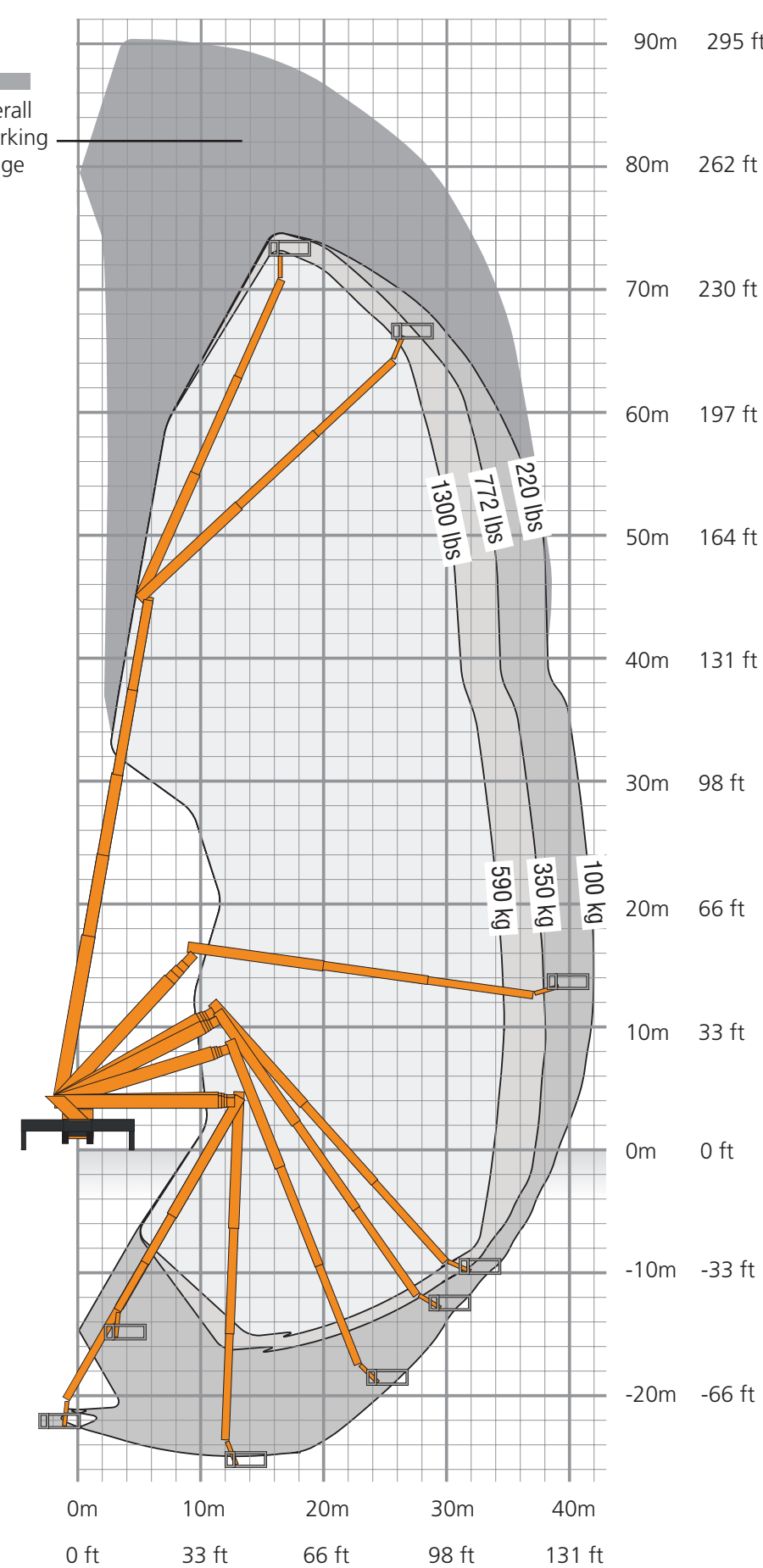

Compact package

- + 295 ft (90 m) working height
- + 137 ft (41.8 m) horizontal outreach
- + 1300 lb. (590 kg) platform capacity
- + 78 ft (23.7 m) below grade reach
- + Dynamic Reach System Available
- + Multi-beveled boom profile
- + Auto outrigger setting and leveling
- + COCKPIT intelligent control system
- + Kenworth T880 Chassis available
- + ANSI A92.2 and CSA C225 compliant

All data has been included without warranty. All measurements and weights are approximate and include optional extras. Technical alterations reserved.

DYNAMIC REACH SYSTEM 