

VO-255/260 REVERSE

Articulated OverCenter Aerial Lift

WORKING HEIGHT: Up to 65 ft 10 in (20.1 m)

HORIZONTAL REACH: Up to 50 ft 8 in (15.4 m)

PLATFORM CAPACITY: Up to 450 lbs (204 kg) for VO-255

**DEMAND
BETTER.
DEMAND
VERSALIFT.**



VO-260 REVERSE model shown here.



VERSALIFT is a leading manufacturer of bucket trucks, digger derricks, aerial lifts and other specialty equipment for power generation, transmission and distribution, investor-owned utility, telecommunications, light and sign, and tree care industries. Working with co-ops, municipalities, government agencies and corporations through its global network of facilities and family of dealers, the company employs nearly 800 associates worldwide.

VO-255/260 REVERSE



Articulated OverCenter Aerial Lift

GENERAL SPECIFICATIONS:

(Based on 40" Frame)

VO-255 REVERSE w/69 in PEDESTAL:

Horizontal Reach Overcenter	46 ft 2 in (14.1 m)
Horizontal Reach Non-Overcenter	41 ft 11 in (12.8 m)
Maximum Platform Capacity	450 lbs (204 kg)
Height to Bottom of Platform	56 ft 4 in (17.2 m)
Working Height	61 ft 4 in (18.7 m)
Stowed Travel Height	12 ft 9 in (3.88 m)
Upper Boom Articulation	270° relative to lower boom
Lower Boom Articulation	125° from horizontal to 35° past vertical

VO-260 REVERSE w/69 in PEDESTAL:

Horizontal Reach Overcenter	50 ft 8 in (15.4 m)
Horizontal Reach Non-Overcenter	46 ft 5 in (14.1 m)
Maximum Platform Capacity	350 lbs (159 kg)
Height to Bottom of Platform	60 ft 10 in (18.5 m)
Working Height	65 ft 10 in (20.1 m)
Stowed Travel Height	12 ft 9 in (3.88 m)
Upper Boom Articulation	245° relative to lower boom
Lower Boom Articulation	125° from horizontal to 35° past vertical

INSULATION:

Upper Boom Insulation	214 in (5.44 m)
Lower Boom Insulation	18 in standard (0.45 m) (24 in optional)

HYDRAULIC SYSTEM:

Operating Pressure	2900 psi (200 bar)
Flow Rate	7 gpm (26 lpm)
Filtration	10 micron return 100 mesh suction
System Type	Open center

OPTIONS:

Backup 12-Volt Pump	Various Platforms, Liners and Covers	Manual Tilt Platform
Tool Port Flow Control	1500 lb Lift Eye	Hydraulic Tilt Platform
Engine Throttle Control	TruGuard™	
Automatic Boom Latch	Category B 46 kV and below, 69 kV	

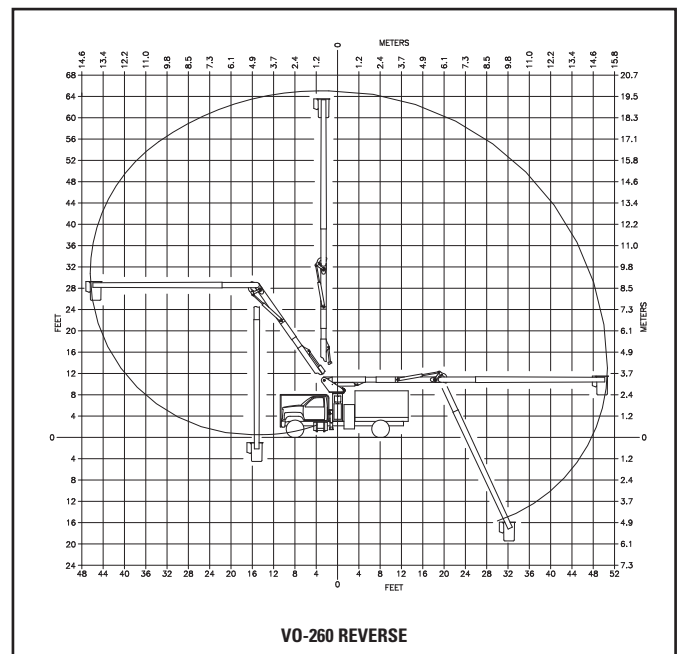
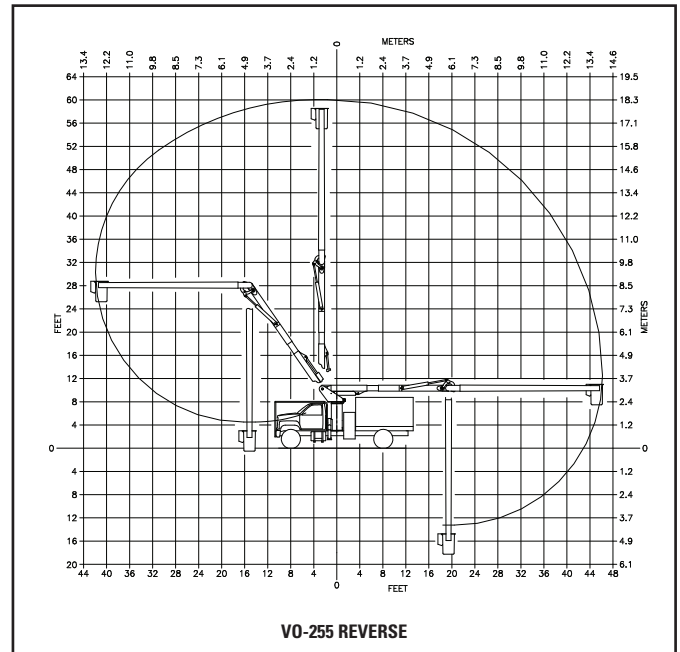

Note: Specifications on units may vary or change without prior notifications due to option selections.