

LIGHTWEIGHT TRUCK BUILT FOR ACCESS.

VERSALIFT
BUILT YOUR WAY

VST-55 | ARTICULATED TELESCOPIC | NON-CDL

Big reach is one thing. Actually using it is another. With a lighter build and more usable payload, the VST-55 makes it easier to get into tighter spaces, move efficiently between jobs and get more done with one truck. Using less fuel along the way is pretty nice, too.

BEST-IN-CLASS PAYLOAD

A lighter build leaves more capacity for what matters, like tools, materials and crew. More usable payload, more job-ready capacity and more builds that stay under CDL.

HEAVY-DUTY PLATFORM CONSTRUCTION

Reinforced fiberglass bucket with up to 600 lb capacity, abrasion-resistant liners and forestry-ready options. Built to handle demanding work where standard platforms fall short.

MATERIAL HANDLING FLEXIBILITY

Add the optional jib and winch to turn your truck into a pick-and-place machine. Lift, move and set up to 1000 lbs without bringing in another piece of equipment.



INDUSTRIES

Municipalities | Electric Utilities

SPECIFICATIONS

Horizontal Reach	33 ft 5 in (10.2 m)
Maximum Platform Capacity	600 lbs (272 kg)
Inner Boom Extension	103 in (2.6 m)
Outer / Inner Boom Articulation	-25° to +80°
Lower Boom Articulation	81°
Rotation	360° Continuous

WITH STANDARD PEDESTAL

Height to Bottom of Platform	54 ft 6 in (16.6 m)
Working Height	59 ft 6 in (18.2 m)
Stowed Travel Height	11 ft 1 in (3.4 m)

INSULATION GAP

Upper Boom Fully Retracted	54 in (1.4 m)
Lower Boom	12 in (305 mm)

HYDRAULIC SYSTEM

Operating Pressure	3000 psi (207 bar)
Flow Rate	6 gpm (22.7 lpm)
System Type	Open Center

Note: Specifications on units may vary or change without prior notification due to option selections.

VST-55 | Articulated Telescopic

REACH DIAGRAM

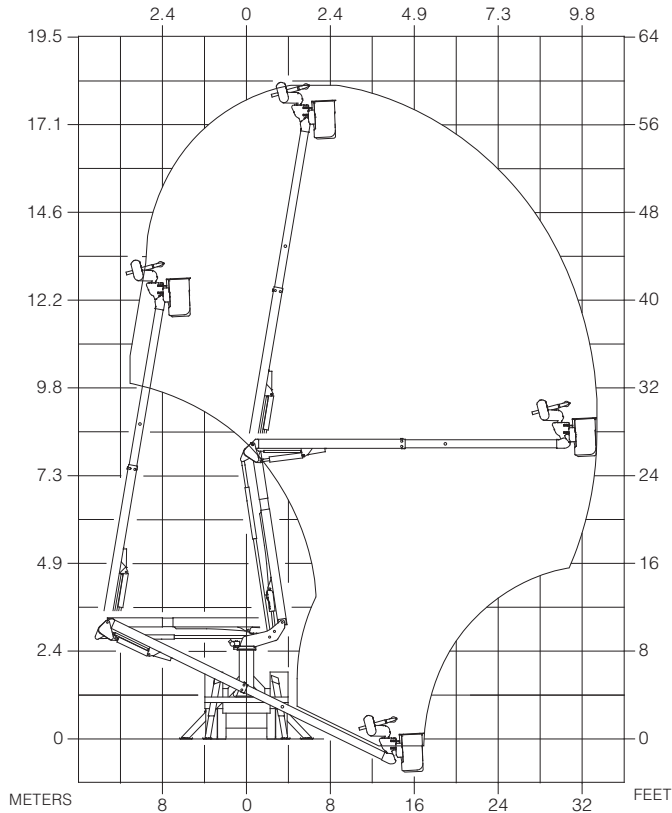

OPTIONS

Outfit your VST-55 for the way your crews actually work. From added stability to expanded tool access and material handling, these options let you dial in the right setup for every job.

- > Auxiliary Outriggers
- > Second Set of Tool Power Ports
- > Platform Elevator
- > Various Pedestal Heights
- > Automatic Boom Latch
- > SlopeMax™
- > Hydraulic Jib/Winch (Reduces Platform Capacity 100 lbs)
- > Jib up to 1000 lb (454 kg) Capacity



800-825-1085
Versalift.com

THE VERSALIFT DIFFERENCE

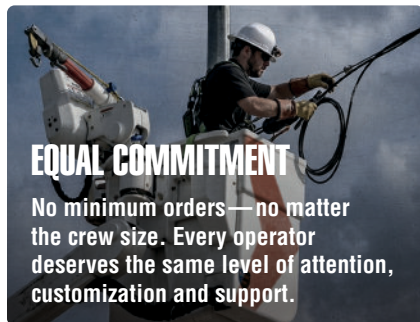

What do you need to get the job done? Versalift answers with trucks, digger derricks and cable placers built around how crews actually work. How you move, what you need and what the job demands. Delivering more payload, better efficiency and less downtime. Because when your truck is Built Your Way, the work just works.

> 7601 IMPERIAL DRIVE | WACO, TEXAS 76712 | 800-825-1085 | VERSALIFT.COM