

VO-265/270-E REVERSE

Articulated OverCenter Aerial Lift w/10 ft Elevator

- **WORKING HEIGHT:** Up to 75 ft 10 in (23.1 m)
- **HORIZONTAL REACH:** Up to 50 ft 8 in (15.4 m)
- **PLATFORM CAPACITY:** Up to 450 lbs (204 kg) for VO-265

**DEMAND
BETTER.
DEMAND
VERSALIFT.**



VO-270 REVERSE model shown here.

VERSALIFT®



VO-265/270-E REVERSE



Articulated OverCenter Aerial Lift w/10 ft Elevator

GENERAL SPECIFICATIONS:

(Based on 40 in Frame)

VO-265 REVERSE WITH ELEVATOR:

Horizontal Reach Overcenter	46 ft 2 in (14.1 m)
Horizontal Reach Non-Overcenter	41 ft 11 in (12.8 m)
Maximum Platform Capacity	450 lbs (204 kg)
Height to Bottom of Platform	66 ft 4 in (20.2 m)
Working Height	71 ft 4 in (21.7 m)
Stowed Travel Height	12 ft 9 in (3.88 m)
Upper Boom Articulation	270° relative to lower boom
Lower Boom Articulation	125° from horizontal to 35° past vertical

VO-270 REVERSE WITH ELEVATOR:

Horizontal Reach Overcenter	50 ft 8 in (15.4 m)
Horizontal Reach Non-Overcenter	46 ft 5 in (14.1 m)
Maximum Platform Capacity	350 lbs (159 kg)
Height to Bottom of Platform	70 ft 10 in (21.6 m)
Working Height	75 ft 10 in (23.1 m)
Stowed Travel Height	12 ft 9 in (3.88 m)
Upper Boom Articulation	245° relative to lower boom
Lower Boom Articulation	125° from horizontal to 35° past vertical

INSULATION:

Upper Boom Insulation	214 in (5.44 m)
Lower Boom Insulation	18 in standard (0.45 m) (24 in optional)

HYDRAULIC SYSTEM:

Operating Pressure	2900 psi (200 bar)
Flow Rate	7 gpm (26 lpm)
Filtration	10 micron return 100 mesh suction
System Type	Open Center

OPTIONS:

- Backup 12-Volt Pump
- Tool Port Flow Control
- Engine Throttle Control
- Automatic Boom Latch
- Various Platforms, Liners and Covers
- 1500 lb Lift Eye
- Category B 46 kV and below, 69 kV
- TruGuard®
- Longitudinal Elevator
- Transverse Elevator
- Hydraulic Tilt Platform
- Manual Tilt Platform

Note: Specifications on units may vary or change without prior notification due to option selections.

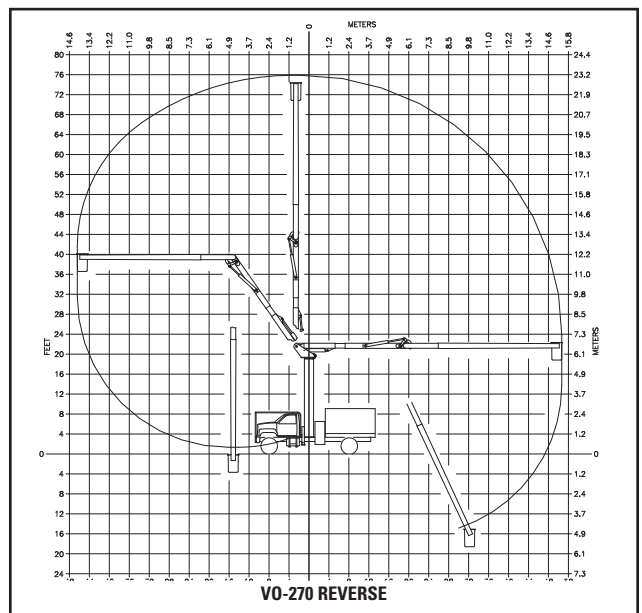
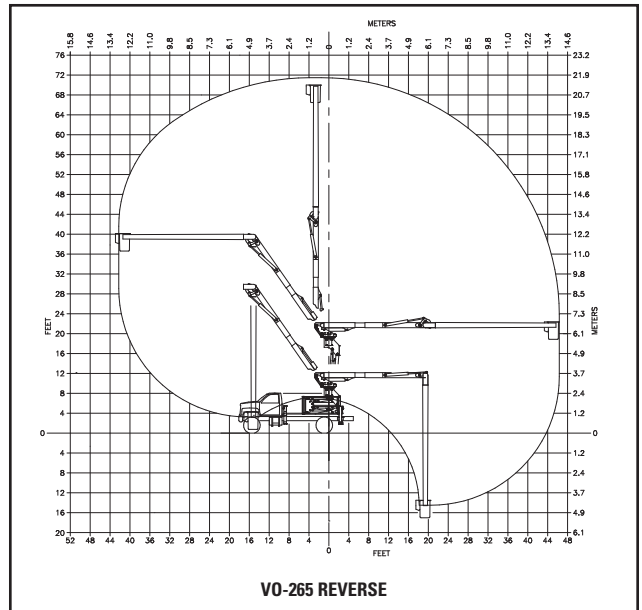

REV. 09/19

VERSALIFT is a leading manufacturer of bucket trucks, digger derricks and cable placers. Customers in the electric utility, telecommunications, forestry and sign, light & traffic industries experience a lower true cost of ownership by choosing Versalift. Our equipment is engineered to be lighter, while keeping the designs simple, which provides advantages like less unscheduled maintenance, greater payloads and ease of maintenance. Versalift has the lowest recall rate in the industry making it the smarter and most reliable choice. Versalift aerial lifts are the only units to feature the patented TruGuard® safety system, which provides additional protection to linemen in the bucket. Versalift is a Time Manufacturing Company, and together with Aspen Aerials has more than 1,000 employees worldwide.

REV. 01/19